

Wafer Head Self Drill Drywall Screw

- Corrosion resistant, self-drilling steel screws with Phillips recess and wafer head
- Ideal for fixing board to stud up to 1.6mm
- Bright zinc finish
- 13mm

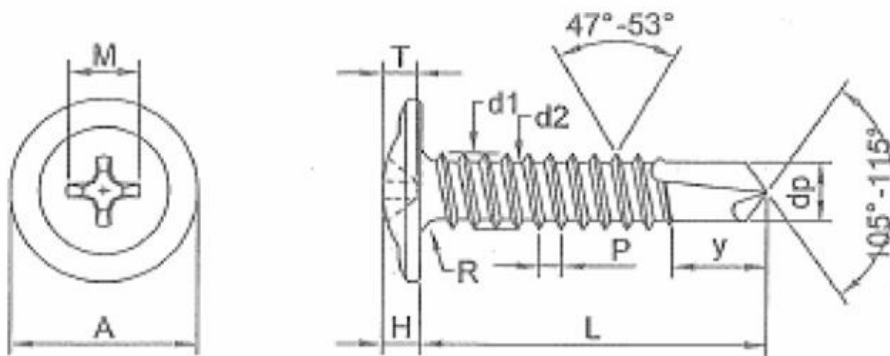

	Head Dia. (A)	H	T	R	d1	d2	y	dp	Drive Size	Pitch (P) +/- 10%
Min Size	10.30	2.00	1.70	0.60	4.09	2.65	4.20	3.35	2	1.41
Max Size	10.70	2.30	2.30	1.00	4.26	2.85	5.60	3.60		

Information	
Length Tolerance	± 0.90mm
Surface Hardness	Min 595 HV
Core Hardness	Max 450 HV
Material	C1018 ~ C1022
Depth of Hardness	M3.5: 0.05 – 0.18mm M3.9 - M4.8 : 0.10 – 0.23mm